

MERCURY 02L HP

Technical specifications

Type of gas Tipo di gas Gastyp Tipo de gas	LPG
Engine maximum power Potenza massima motore Für Motoren mit Leistungen bis zu Para motores con potencia hasta	115 kW
Gas outlet pressure Pressione gas in uscita Ausgangsdruck Presión de salida	1,2 bar
Gas inlet Ingresso gas Eingang gaz Entrada gas	Female connection with ferrule for \varnothing 6 mm pipe Connessione femmina con ogiva per tubo \varnothing 6 mm Rohranschluss mit Innengewinde und Ogive \varnothing 6 mm Conexión hembra con virola para tubo \varnothing 6 mm
Gas outlet Uscita gas Ausgang gaz Salida gas	Male connection for rubber hose \varnothing_{int} 12 mm Connessione maschio per tubo in gomma \varnothing 12 mm Steckanschluss für Gummischlauch \varnothing 12 mm Conexión macho para tubo de goma \varnothing 12 mm
Engine cooling liquid Inlet/Outlet Ingresso/uscita liquido di raffreddamento Ein-/Ausgang Kühlfüssigkeit Entrada/salida líquido de refrigeración	Male connection for rubber hose \varnothing_{int} 16 mm Connessione maschio per tubo in gomma \varnothing 16 mm Steckanschluss für Gummischlauch \varnothing 16 mm Conexión macho para tubo de goma \varnothing 16 mm
Cut off automatic valve + Filter Elettrovalvola + Filtro Magnetventil + Filter Electrovalvula + Filtro	Present (Red. inlet) - IP 54 electrical connection Presente (Ingresso rid.) - Connessione elettrica IP54 Gegeben (Eingang reg.) - Stromanschluss IP54 Presente (Entrada red.) - Conexión eléctrica IP54
Solenoid valve nominal voltage Tensione nominale elettrovalvola Nennspannung Magnetventil Tensión nominal electrovalvula	12 V d.c.
Solenoid valve nominal power Potenza nominale elettrovalvola Nennleistung Magnetventil Potencia nominal electrovalvula	11 W (12 V)
Manifold pressure nozzle Presa di pressione collettore Anschluss für Kollektorkompensation Enlace para compensación al colector	Present (integrated) Presente (integrata) Gegeben (eingebaut) Presente (integrada)
Reducer temperature sensor Sensore di temperatura riduttore Temperaturfühler Druckminderer Sensor de temperatura regulador	Optional Opzionale Sonderzubehör Opcional
Pressure relief valve Valvola di sicurezza Sicherheitsventil Válvula de seguridad	Present (integrated) Presente (integrata) Gegeben (eingebaut) Presente (integrada)
Gas pressure reduction stages Stadi di riduzione di pressione gas Reduzierstufen Etapas de reducción	2 2 2 2
Operating temperature Temperatura di funzionamento Betriebstemperatur Temperatura de funcionamiento	- 20° / +120°C
Overall dimensions Dimensioni d'ingombro Äußere Abmessungen Dimensiones	146 x 125 x 98,5 mm
Homologations Omologazioni Zulassungen Homologaciones	R67-01 R67-01 R67-01 R67-01

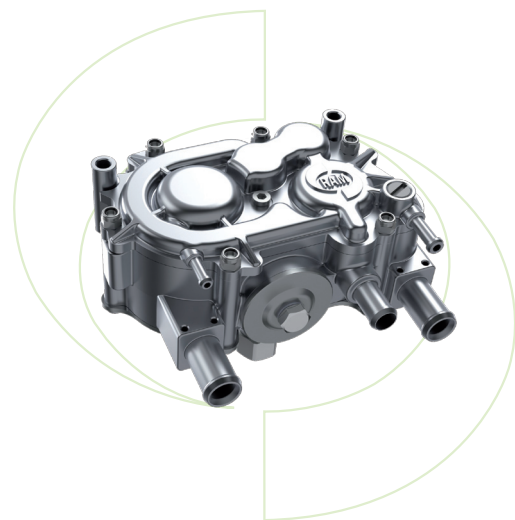

MERCURY regulators are easy to install, due to the fact that gas, air and water connections are in the same direction and close each other.

High heat exchange surface guarantees the full LPG vaporization, in any operating condition.

The Mercury 02L has a solenoid valve with filter at reducer inlet. This avoids to have overpressure inside the reducer, when switching from gas to gasoline. The installation of any filter, in the liquid LPG line, is avoided.



I riduttori della famiglia MERCURY sono di facile installazione, data la vicinanza e lo stesso orientamento delle varie connessioni acqua, gas e aria.

L'elevata superficie di scambio termico, garantisce la completa vaporizzazione del GPL in ogni condizione di impiego.

Il Mercury 02L è dotato di un'elettrovalvola con filtro in ingresso al riduttore. Ciò consente di non installare alcun filtro sulla linea del GPL liquido ed evita l'eccessiva sovrappressione all'interno del riduttore, al momento del passaggio da gas a benzina.



Die Druckminderer der Familie MERCURY sind aufgrund der Nähe und der Ausrichtung der verschiedenen Wasser, Gas- und Luftanschlüsse ausgesprochen installationsfreundlich.

Die hohe Wärmetauscherfläche gewährleistet die komplette Verdampfung des Flüssiggases unter jeder Anwendungsbedingung.

Mercury 02L ist mit einem Magnetventil mit EingangsfILTER zum Druckminderer ausgestattet. Hierdurch kann es unterlassen werden, einen Filter in der Flüssiggasleitung zu installieren und man vermeidet beim Umschalten von Gas auf Benzin einen exzessiven Überdruck im Druckminderer.



Los reductores de familia MERCURY son de fácil instalación, dada la proximidad y la misma orientación de las distintas conexiones agua, gas y aire. La elevada superficie de intercambio térmico, garantiza la completa vaporización del GPL en cualquier condición de utilización.

Mercury 02L está dotado de una electrovalvula con filtro de entrada al reductor. Esto permite no instalar ningún filtro sobre la línea del GPL líquido y evita la excesiva sobre presión en el interior del reductor, en el momento del pasaje de gas a gasolina.



RAM Regulators srl

Via Col. A. Varisco, 12 - 35010 Vigonza (PD) - ITALY

tel. +39 049 6226456 - fax +39 049 8953685 - www.ramregulators.com - info@ramregulators.com - P.Iva e C.F. 04200220269

MERCURY 02L HP

Technical design and dimensions

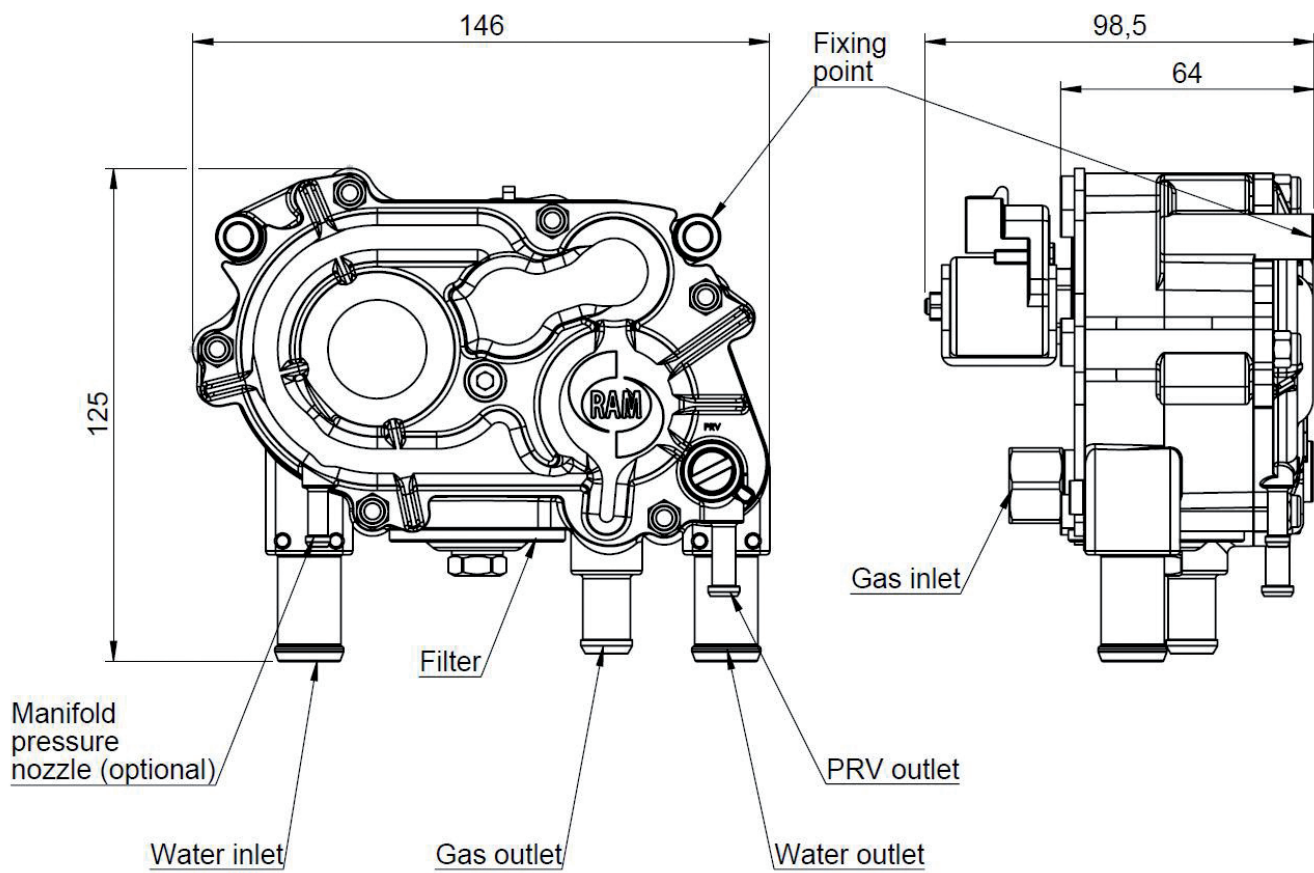
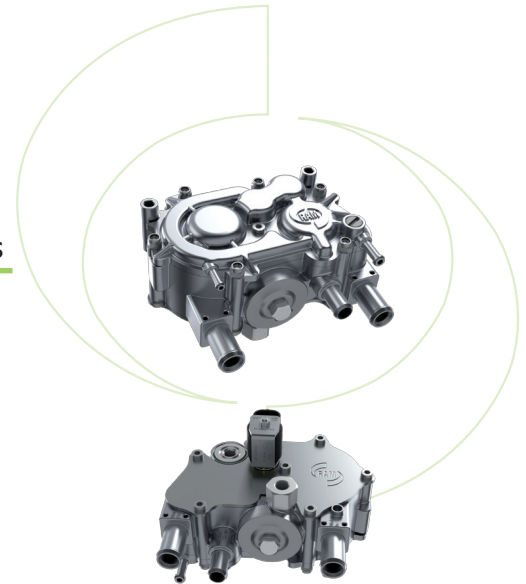

RAM Regulators srl

Via Col. A. Varisco, 12 - 35010 Vigonza (PD) - ITALY

tel. +39 049 6226456 - fax +39 049 8953685 - www.ramregulators.com - info@ramregulators.com - P.Iva e C.F. 04200220269